

General Information

Applications	2
Safety instructions	2
Intended Use	3
Technical Terms of Reference / Transport.....	3

The Light Weight Deflectometer

Construction of the Instrument.....	4
Function	5
Specifications	5
Operation of Electronic Settlement Measuring Instrument.....	6

Measuring

Getting Ready for Measuring	7
Measuring Procedure	8
Store and Print Current Measured Data.....	9
Completing the Test	10
Error Menus	10

Measured Data

Read / Print the Stored Measured Data	11
Transfer the Stored Measured Data.....	11
Delete Measuring Results	12

Settings

Display	13
Device	13
Printer.....	13

Options

Thermal printer AP1300.....	14
GPS Receiver.....	16

Maintenance and Repair

Cleaning.....	19
Calibrating	19
Hotline.....	19

Attachment

- 1 Certificate „BAST-authorized calibration institute ...“
- 2 Certificate of Conformity

Applications

The dynamic plate load test employing the Light Weight Deflectometer is used in earthworks and traffic route construction. It serves to determine the soil bearing capacity and the degree of compaction of soils and non-cemented base courses, and assists in soil improvement.

The test method is suited for coarse-grain and mixed-grain soils with a maximum grain size of 63 mm. It may be used to determine the deformation modulus of soil within the measuring range of $E_{vd} = 15 \dots 70 \text{ MN/m}^2$.

Further applications

- Road- and railway construction, earthworks
- Quality assurance in canal construction
- Compaction control in pipe trenches
- Testing of pavement beddings
- Testing of foundation backfill
- Quality inspection in boreholes
- Testing of modulus of deformation within the framework of soil examination.

The Light Weight Deflectometer being easy to handle and use is particularly suited for intra-company monitoring.

Safety instructions

Information for Users

This instruction manual was prepared such that users can easily become familiar with the »Light Weight Deflectometer – LWD«, abbreviated herein-after as LWD, and make use of the tester for intended applications.

Users should carefully read this instruction manual and the safety instructions prior to using the LWD. Follow the instructions contained in this Instruction Manual without exception.

Symbols Used

Warnings and instructions are highlighted as described below:



Warning

This symbol is used in conjunction with related text to draw user's attention to hazards and risks which may cause bodily harms, failure of tester components or adversely affect operating procedures, in case users do not take the corresponding precautions.



Note

This symbol and the related text identify technical requirements and provide additional information to be taken into account by the operator to carry out the following operations effectively and safely.

Legal Terms of Reference

The Light Weight Deflectometer complies with the current state of the art and all applicable safety regulations.

The LWD meets the basic safety requirements laid down in the EU Directives for Harmonisation referenced in the EC Certificate of Conformity.

Construction and function of the LWD meet the requirements laid down in »Technical Test Code for Soil and Rock in Road Construction TP BF – StB Part B 8.3 / Issue 2012« and »ASTM E2835-11 – Standard Test Method for Measuring Deflections using a Portable Impulse Plate Load Test Device«.

Intended Use

The Light Weight Deflectometer is exclusively intended for determining the soil bearing capacity and the compaction quality of the soil referred to »Technical Test Code for Soil and Rock in Road Construction TP BF – StB Part B 8.3 / Issue 2012« and »ASTM E2835-11 – Standard Test Method for Measuring Deflections using a Portable Impulse Plate Load Test Device«.

Its intended use also includes:

- Compliance with the safety instructions and safety regulations contained in this operating manual;
- Compliance with the maintenance and servicing instructions contained in this operating manual.

Any other use or any use beyond this definition is not intended and may cause injury to people and damage to property.

The manufacturer/supplier shall not be held liable for damages resulting from other than the intended use. The risk shall be borne solely by the user.

Technical Terms of Reference / Transport

To avoid damage to the unit and prevent accidents during transport the Light Weight Deflectometer is provided with a transportation lock which is fixed to the guide tube during transport.



The LWD is equipped with a transportation lock designed to avoid damage to the instrument and make sure that it can be safely transported and handled. This lock must be used to secure the drop-weight on the guide tube whilst the equipment is moved from job to job.

The drop height determined for the drop-weight by calibration (→ calibration record) has been preset. The drop height is secured against changes and must not be altered by the user.

Engage the drop-weight in the release mechanism prior to any test. To release the drop-weight, just actuate the release mechanism.



Prior to any measurement, test the release mechanism to be sure it functions as necessary. Support the drop-weight by hand after every impact to avoid faulty measurements.

Construction of the Instrument

The LWD consists of the following assemblies:

- Loading mechanism
- Load plate
- Electronic settlement measuring instrument

Loading Mechanism and Load Plate

Construction of the loading mechanism and the load plate is described with reference to the figure below.

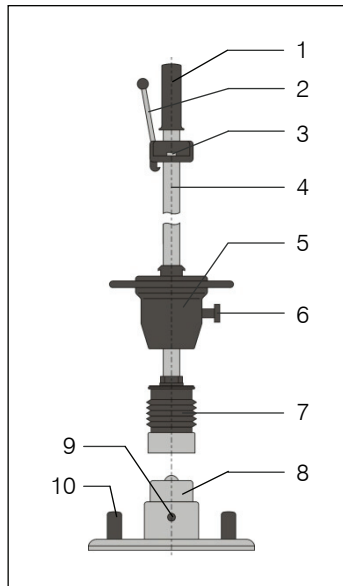

Loading mechanism

- | | |
|-----------------------|---|
| 1 – Handle | 5 – Drop-weight |
| 2 – Release mechanism | 6 – Transportation lock |
| 3 – Bubble level | 7 – Resilient element with prestressed disc springs |
| 4 – Guide tube | |

Load plate

- 8 – Cap with sensor
- 9 – Sensor socket (to connect the measuring cable)
- 10 – Load plate carrying handles

The sensor which serves to measure the settlement is arranged under the cap (8) of the load plate. The leads of the sensor are led out on the sensor socket (9) and are connected to the electronic settlement measuring instrument via a measuring cable.

Electronic Settlement Measuring Instrument

The battery-operated settlement measuring instrument is housed in a hand-held case.

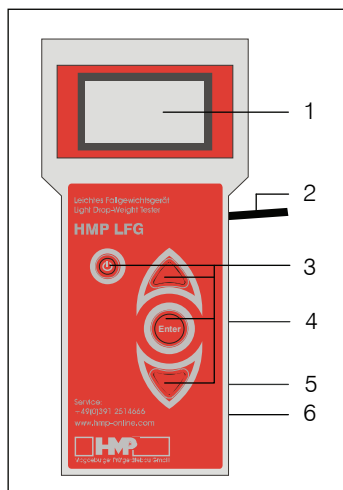

Settlement measuring instrument

- 1 – LCD graphic display
- 2 – Measuring cable outlet
- 3 – Function keys
- 4 – USB port
- 5 – GPS port
- 6 – Printer port

Carrying case

- 1 – Carrying case
- 2 – Settlement measuring instrument
- 3 – GPS receiver (optional)
- 4 – Charger for thermal printer AP1300 (optional, beneath the measuring instrument)
- 5 – Thermal printer AP 1300 (optional)



Function

The load plate is placed on the prepared area to be tested and the loading mechanism is positioned on the load plate. Thereafter the connection is made to the settlement measuring instrument. When the drop-weight is released and drops freely onto the resilient element, the loading mechanism generates a defined impulsive load. Thereby the total settlement of the soil under the load plate is measured.

After the measuring routine is started (after the precompaction) three measuring impacts are to be performed. After each impact, the measuring instrument displays the settlement in millimetres. Upon completion of a series of measurements the individual settlement amplitudes, the average settlement S_m , the path-speed-ratio (s/v) and the calculated deformation modulus E_{vd} are displayed on the screen.

Results may be printed via a thermal printer or a printer at the PC, if required (*only instruments with thermal printer or PC-software*).

Specifications *

Mechanical loading mechanism

Total weight	15.0 kg
Weight of drop-weight	10.0 kg
Maximum impact force	7.07 kN
Duration of impact	17.0 ± 1.5 ms
Resilient element	package comprising prestressed disc springs

Load plate

Diameter	300 mm
Plate thickness	20.0 mm
Weight	15.0 kg





Electronic settlement measuring instrument

Power supply	4 of - R6 batteries or rechargeable batteries
Dimensions	211 mm x 100 mm x 45 mm
Weight	0.47 kg
Settlement range measured	0.1 to 2.0 mm \pm 0.02 mm
Measuring range for deformation modulus	$E_{vd} < 225$ MN/m ²
Temperature range	0 to 40 °C

Operation of Electronic Settlement Measuring Instrument

The electronic settlement measuring instrument **HMP LFG4** can be operated easily and intuitively by means of the function keys.

Key Functions

-  Switch on / off measuring instrument
-  Select upward
-  Select downward
-  Confirm selection / Start action

Overview Menu Functions

Measuring	Taking measurement	
Measured data	Read/Print	
	USB	
	Delete	
	Back	
Settings	Display	Date
		Time
		Language
		Back
	Device	Drop weight
		GPS
		Unit
		Calibr.date
		Back
	Printer	Print head
		Date/time
		Graphics
		Contact data
		Back
	Back	

By confirming the menu item »Back« you always come back to the previous menu.

Getting Ready for Measuring



The procedure of preparation and performance of measurements is laid down in »Technical Test Code for Soil and Rock in Road Construction TB BF-StB Part B 8.3 / Issue 2012 – Dynamic Plate Load Test by means of the Light Weight Deflectometer« and in »ASTM E2835-11 – Standard Test Method for Measuring Deflections using a Portable Impulse Plate Load Test Device«.

Preparing the area to be tested

The load plate must be in full-area contact, so that the impact force can be optimally transmitted to the ground and the maximum settlement amplitude under the entire area of the load plate is determined.

- Select a plain area on the measuring site.
- Position the load plate while slightly turning and pushing.
- Fill hollow spaces under the load plate if necessary with loose medium sand.

Connecting the settlement measuring instrument

- Connect the sensor, which is located under the cap (8) of the load plate, via sensor socket (9) with the settlement measuring device.
 - Remove the cap from the sensor socket.
 - Insert the plug of the measuring cable from the settlement measuring instrument into the sensor socket until it is locked.



The plug locked in the sensor socket can only be removed by pulling on the plug housing. Do not pull on the cable. Take care to ensure that the contacts of the plug and the sensor socket are not damaged. Use the protective cap provided on the cap (8) to protect the sensor socket from dirt and moisture.

Positioning the loading mechanism

- Position the loading mechanism on the cap of the load plate.
 - ⇒ The tilt protection enables free standing of the loading device on the load plate.

Removing the transportation lock

A transportation lock (6) is provided to secure the drop-weight on the guide tube. This lock must be released prior to performing measurements.

- Withdraw red knob.
- Rotate red knob through 90 deg.

The arrow is horizontal: either  or  drop-weight is locked

The arrow is vertical: either  or  drop-weight is unlocked



The transportation lock has to be unlocked before measuring, otherwise mis-measurements and damages of the guide tube can be caused.

Precompacting the test area

To achieve an optimal position of the load plate on the base the test area under the load plate should be precompacted by three impacts.

- Move the drop-weight fully up on the guide tube with the right hand and lock it in the release mechanism.
- Use the bubble level (3) to align the guide tube until it is in vertical position to the soil.
- Release the lever, the drop-weight falls onto the resilient element package.
- Catch the rebounding drop-weight by hand and lock it back in the release mechanism.

Repeat this procedure twice.

Measuring Procedure



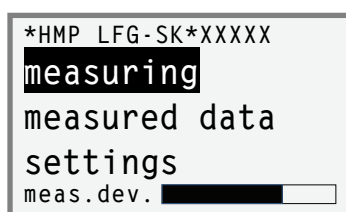

The base settings of the electronic settlement measuring instrument comply with the ordered device type.

Individual adjustments can be carried out in the »Settings« menu (→ page 19).



- Press the  key to switch on the settlement measuring instrument.
 - ⇒ The main menu shown on the left is displayed on the LCD screen with type and number of device (xxxx), the individual menu items and the voltage state of the measuring instrument batteries.

Optionally a note regarding the state of charge of the printer accumulator (after pressing the   keys) appears.

In case the settlement measuring instrument is equipped with a Bluetooth interface optionally the note »HMP-LFG-BT Power on GPS!« appears, shortly after the main menu is displayed.



In case that the measuring instrument battery voltage falls below the required minimum voltage, an additional advice »Change« appears.

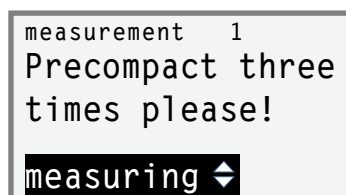

- Please confirm the »Measuring« mode by pressing the  key.
 - ⇒ The menu shown on the left is displayed on the LCD-screen.
 - ⇒ At the same time the user information »Precompact three times please!« appears.

If the soil was not precompacted yet, please follow the instructions in section »Precompacting the test area« (→ page 7).

- Start the measuring process by pressing the  key.
 - ⇒ An acoustic signal is emitted and on the screen appears the request »measuring initiate«.



The readiness for measurement only insists during displaying »measuring initiate«.

- Successively perform 3 impacts as follows.
- Lock the weight in the release mechanism.
- Use the bubble level to align the guide tube until it is in a vertical position to the load plate.
- Release the lever, the drop-weight falls down, catch the rebounding drop-weight by hand.
 - ⇒ The values of settlement amplitudes S1, S2 and S3 are displayed on the screen.

```

measurement 1
#.### #.### #.###

Sm= #.###mm s/v= #.##
Evd= ##.##MN/m2
save ▾
    
```



Failure to catch the rebounding drop-weight may cause undesirable compaction of the test area and, hence, faulty measurements.

The series of measurements is automatically completed after the third measurement. The menu on the left is displayed on the LCD-screen including the individual settlement amplitudes and the average settlement S_m as well as the path-speed-ratio s/v and the calculated E_{Vd} -value.

```

measurement 1
#.### #.### #.###

Sm= #.###mm s/v= #.##
Evd= ##.##MN/m2
save ▾
    
```

Store and Print Current Measured Data

Upon completion of one test series the current measured data can be stored or rejected. Furthermore there is also the possibility to print the current test series (*only devices with printer*) as well as to display the GPS-data (*only if a GPS-receiver is connected*).



The GPS data can only be shown, when the item GPS is activated in the Settings / Device menu.



Before using the thermal printer AP1300 please read the instruction manual (→ page 13-16) and follow the given instructions regarding putting it into operation and handling.

By pressing the \triangle ∇ keys the following functions can be chosen (depending on the device settings):

- | Save: Store the current test series under the displayed test series number
- | Delete: Delete the current test series and return to main menu
- | Print: Print out the current test series
- | GPS-data: Displaying the GPS-position
- | Settlement data: Displaying the individual settlement amplitudes and the average settlement S_m as well as the the path-speed-ratio s/v and and the calculated E_{Vd} -value
- | Back: Return to main menu

The function »Delete« is only available before storing and the function »Back« only after storing. Displaying the GPS-position is only possible after storing.



As soon as the message »Memory full!« appears on the LCD display, storage space in the measuring instrument has to be created by transferring the stored series of measurements to the USB-Stick or the PC (→ page 11) and subsequent deletion (→ page 12).



It is recommended to transfer the test series and measurement results stored in the measuring instrument regularly onto the provided USB-Stick or to the PC (→ page 11) and to delete afterwards the data in the measuring instrument (→ page 12).

In this way the transference time will be shortened and multiple data transfer avoided.

Completing the Test

- Press the  key to switch off the settlement measuring instrument.
- Disconnect the cable establishing connection between the settlement measuring instrument and the sensor on the load plate.
 - Remove the plug from the socket by pulling on the plug enclosure.
- Replace the cap on the sensor socket.
- Lock the drop-weight by means of the transportation lock.
 - Withdraw red knob.
 - Rotate red knob through 90 deg.
 - At the same time, rotate the drop-weight in the lowermost position until the pin locks into the hole in the guide tube.

The arrow is horizontal: either  or  drop-weight is locked



The LWD may not be relocated before the drop-weight is fixed by means of the transportation lock.

Error Menus

To monitor the measuring procedure the measuring instrument provides instructions which pops up as an error report before measurement or when an individual measurement is aborted.

The following error reports might appear before the measurement:

Error report	Error cause
connect meas. dev. to plate	no connection between measuring instrument and load plate (plug was not connected to the plate, measuring cable defective, plug demolished)
short circuit in meas. cable	no correct connection between measuring instrument and load plate or measuring cable is damaged

- Check / establish the connection.
- Restart the measuring process by pressing the  key, as soon as the connection is correct.

The following error reports might appear when the measurement is aborted:

Error report	Error cause
MW < 0,1	The settlement amplitude is lower than 0.10 mm. Reason: The drop-weight was locked »hard« back in the release mechanism or when measuring a strongly compacted underground.
no minimum	No pronounced minimum of the settlement amplitude was found during measurement. Reasons: - faulty pulse, caused by a damaged guide tube for example - measurement was started too earlier

- In both cases restart the measuring procedure by pressing the  key.

Read / Print the Stored Measured Data

read/print

USB

delete

back

no.	date	time	Evd
1	04.06	08:34	58
2	04.06	08:47	57
3	04.06	11:32	61
4	04.06	11:45	59

scroll backward
scroll forward
back

The in the database stored test series and -results can be displayed via menu item »Read/Print« on the LCD-screen and printed out if required.



Before using the thermal printer AP1300 please read the instruction manual (→ page 13-16) and follow the given instructions regarding putting into operation and handling.

- Choose and confirm the desired test series.
⇒ The values of the chosen test series are displayed on the LCD-screen.

By pressing the \triangle / ∇ keys, the following functions can be used (depending on the device settings):

- Print: Printing the current test series
- GPS-data: Displaying the GPS-position
- Settlement data: Displaying the individual settlement amplitudes and the average settlement S_m as well as the the path-speed-ratio s/v and and the calculated E_{vd} -value
- Back: Return to the previous menu

read/print

USB

delete

back

device->USBstick

device->PC

back

Transfer the Stored Measured Data

The test series and –results stored in the database can be transferred via menu item »USB« to the supplied USB stick or to PC.



Data Transfer Measuring Instrument → USB Stick

- Connect the USB stick to the measuring instrument.
- Choose transfer mode »Device → USB stick« and confirm by pressing Enter
⇒ On the LCD display appears the inquiry »USB stick connected?«
- Confirm this inquiry by pressing the Enter key.
⇒ The data are being copied to the USB stick.
⇒ After completion of data transfer the measuring instrument switches off automatically.

To transfer the data from the USB stick to the PC see instruction manual »Protocol software for the Light Weight Deflectometer«.

device -> USBstick
 device -> PC
 back

Data Transfer Measuring Instrument → PC



- Connect measuring instrument and PC via the supplied USB cable.
- Choose transfer mode »Device → PC« and confirm by pressing .
 ⇒ On the LCD display appears the inquiry »PC connected?«
- Confirm the inquiry by pressing the  key.
 ⇒ The measuring instrument works now just like removable media.
- After completion of data transfer to PC remove the removable media and switch off the measuring instrument.

To transfer data from measuring instrument to PC see instruction manual »Protocol software for the Light Weight Deflectometer«.

read/print
 USB
 delete
 back

Delete Measuring Results

The test series and -results stored in data base can be deleted via menu item »Delete«.

- Confirm menu item »Delete« by pressing  key.
 ⇒ On the LCD screen is displayed the choice »measurement delete« or rather »not delete«.
- Confirm »measurement delete« by pressing the  key.
 ⇒ All measurements will be deleted.



Stored series cannot be deleted individually.

Display

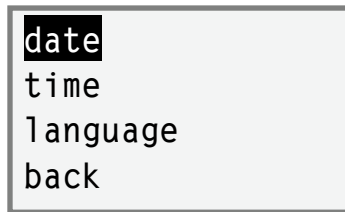

Under the menu item »Display« the following settings can be carried out:

- Date set date
- Time set time
- Language choose language
- Back return to previous menu

Device

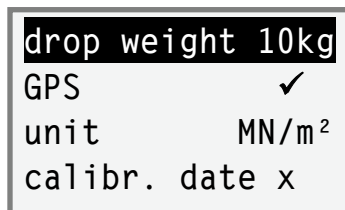

Under the menu item »Device« the following settings can be carried out for device configuration:

- Drop Weight (10 kg / 15kg¹⁾) set configuration of loading mechanism
- GPS (✓ / x) activate / deactivate GPS
- Unit (MN/m² / MPa) set unit
- Calibr. date (✓ / x) show / don't show calibration date on start screen
- Back return to previous menu

1)



The configuration 15 kg is only allowed to be used for a loading mechanism with a drop-weight of 15 kg. There is a separate test code for this.

Printer

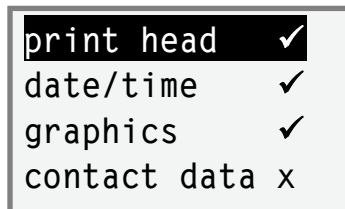

Under the menu item »Printer« the following settings can be carried out for printer configuration:

- Print head (✓ / x) Print head »✓« means, that always on every printout the head with information regarding measuring point will be printed out. Print head »x« means, that the first printout is with head, all others without. This setting is paper-saving and is used f. e. to print out an inspection lot.
- Date / Time (✓ / x) print out date / time
- Graphics (✓ / x) print out curve
- Contact data (✓ / x) print out company data (*optional*)
- Back return to previous menu

Contact Data

In particular, these are the company details of the device owner, which can optionally be printed out in the protocol head.

The company details are not programmed by default. This requires a file with the desired data, which could be provided on request and would have to be installed on the electronic settlement measuring instrument.

Thermal printer AP1300

Included in the Light Weight Deflectometer's scope of supply is a thermal printer AP1300 (*optional*).

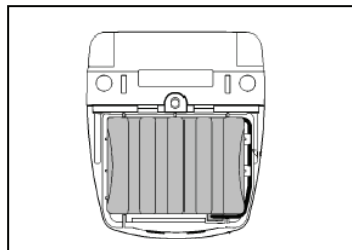

Power Supply

The printer can be operated independently from a power supply unit and is powered by a 1.8 Ah NiMH power pack housed in the printer. Thus, the printer can be carried from job to job.

Safety



- ! The NiMH power pack is provided with an internal fuse unit. However, a short-circuit may occur when the NiMH power pack gets into contact with metallic items.
- ! The power pack must not be opened; otherwise it may leak out or a short-circuit may occur
- ! Before you remove or replace the power pack, disconnect it from the external power pack charger.

The power pack has to be charged only by means of the supplied power pack charger. The power pack charger can be connected with a car-battery 12–24V or by means of an AC-adapter to mains 100–240V / 50–60Hz. The AC-adapter is included in the delivery contents and is placed in the case together with the charger beneath the measuring instrument.

The printer AP1300 is shipped with a connected and fully loaded power pack.



- ! When the printer is used for the first time after a lengthy period or has been standing idle for a lengthy period, recharge the power pack prior to use.
- ! In the event of malfunction the printer may only be opened by authorised personnel.



- ! The supplied accessories must only be used for devices supplied by HMP and according to this instruction manual. Any other use may cause damages.

Charging of Power Pack



- ! For Changing the power pack it is only allowed to use the supplied power pack charger
- ! Fully charging the power pack takes 15 hours at most.
- ! Use the power pack charger only indoors. Disconnect the device from the mains if it is not used. Do not operate the device in case of damage to the housing or the mains plug.
- ! Only charge nickel/metal hydride power packs; use of the charger for other batteries may cause an explosion hazard.
- ! Do not open the power pack charger.

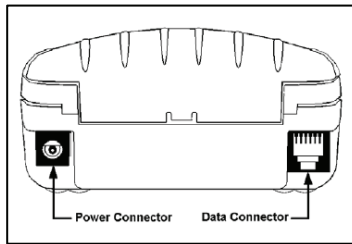

- Connect the power pack charger to the »Power Supply« connection of the printer.
- Connect the power pack charger to the mains supply.
- Disconnect the power pack charger from the mains supply when charging of power pack has been finished (after 15 hours at the latest).

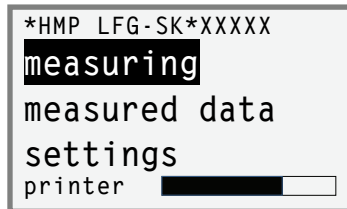

State of Charge of the Printer

The state of charge of the printer is displayed in the lower area of the LCD-screen after switching on the measuring instrument (after pressing the \triangle ∇ keys).



In case that the accu pack of the printer falls below the required minimum voltage, the request »Load printer« is displayed.

Front Panel of Printer

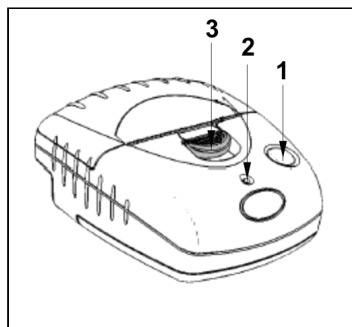

- | | |
|------------------------------|--|
| 1 – Paper feed | <p>Single-line paper feed:</p> <ul style="list-style-type: none"> – Press the key for a short interval, and release. <p>Multi-line paper feed:</p> <ul style="list-style-type: none"> – Hold down this key until the desired length of paper is reached. |
| 2 – LED | <p>Signals READY</p> <p>LED off:</p> <ul style="list-style-type: none"> – The printer is in the power-saving mode. – Power pack is discharged. <p>Green LED (steady):</p> <ul style="list-style-type: none"> – Printer is active. <p>Green flashing LED:</p> <ul style="list-style-type: none"> – Paper out. <p>Green – orange flashing LED:</p> <ul style="list-style-type: none"> – Power pack is charged <p>Red – green flashing LED:</p> <ul style="list-style-type: none"> – Power pack voltage is too low. |
| 3 – Paper compartment opener | |

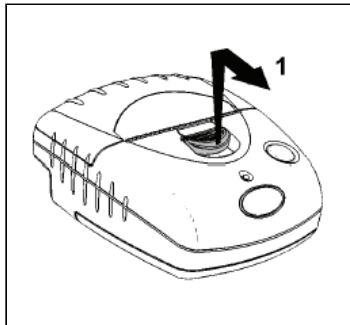

Insert Paper Roll

- Push the paper compartment opener to the front until the printer lid opens (1).
- Unwind a few centimetres of the new roll and load the paper roll into the compartment such that the paper will unwind from below (2).
- Close the printer lid (3).
- Press the paper feed key to check the correct paper movement.
- Excessive paper is rapidly torn off by using the cutting edge.

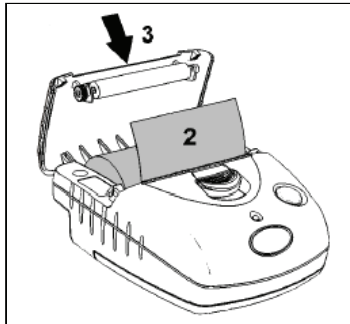

The thermal printer AP1300 is provided with sensors to detect lacking paper or opened paper compartment. If a sensor is activated, the printer switches to the storage mode; all data transmitted to the printer are preserved. Printing is continued immediately as soon as the defect has been removed.



It is recommended using original paper roles for thermo printer only, dimensions: Ø 3 cm, width 5.7 cm (length of paper 10 m).

Malfunction

Printer fails to start printing:

- Connection correct? Check connections.
- Has the printer automatically switched on and is the LED on?
- Is the power pack discharged? Charge the printer before use.

GPS Receiver

The Light Weight Deflectometer **HMP LFG4** is optionally equipped with an external highly sensitive GPS receiver to determine the measuring position.

The coordinates are captured fast and exactly, because of newest technology, and transferred to the measuring instrument **HMP LFG4** where they are associated to the corresponding test and saved in the device.



Basis for the determination of the measuring position with the GPS receiver is a measuring location, where the device has free reception.



Before using the GPS receiver users have to read the original user manual. Users must observe all safety instructions and warnings included in the original user manual, to avoid injury, electric shock, fire and damages on the device.

The original user manual is stored on the USB Stick included in the scope of supply of HMP LFG4.

Scope of supply of GPS receiver

- Bluetooth GPS receiver including battery pack
- Car charger
- USB-cable

Operation GPS Receiver

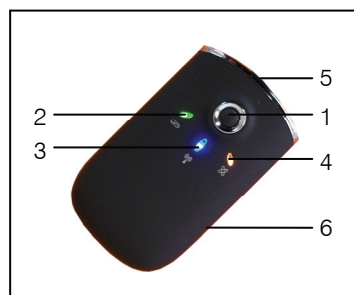

- 1 – On/Off button
- 2 – Battery status LED
- 3 – Bluetooth status LED
- 4 – GPS status LED
- 5 – USB port
- 6 – Battery compartment cover

LED Indication

- 2 – Blinking red: Battery status is not enough
- 2 – Blazing green: when recharge the battery
- 3 – Blinking blue: Bluetooth ready, no connection
- 3 – Blazing green: Bluetooth connection established
- 4 – Blazing orange: Position not yet determined
- 4 – Blinking orange: Position determined

Power Supply / Recharging Battery

The GPS receiver is powered by Lithium-Ion-Battery.



The GPS logger's power may be supplied only by the included rechargeable battery. Please use only the original accessory and never charge the rechargeable battery with a charger from other producers.

In case the battery status LED (2) of the GPS receiver is blinking red, the battery has to be recharged.

- Plug the USB cable with the bigger connector into an USB port of PC or into the car charger. Connect the car charger to a car's cigarette lighter socket.
- The Mini USB connector has to be plugged into the USB port (5) of the GPS receiver.
 - ⇒ The Battery status indication LED is blazing green.
- Charge the battery completely.
- Unplug the USB cable after the green LED turned off.

Use GPS Receiver

Shall the GPS receiver be used, proceed as follows

- Press On/Off button (1) for about 2 seconds to switch on the GPS receiver.
 - ⇒ Initialization and determination of the position (lasts at least 1 minute).



If the GPS receiver is used for the first time, the first determination of position can take up to 30min. The same can happen when the receiver is used on another continent.

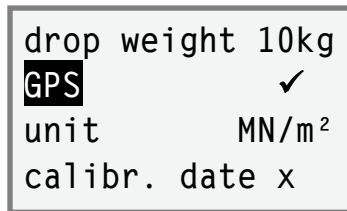

- Press the  key to switch on the settlement measuring instrument.
 ⇒ On the display the note »HMP-LFG-BT Power on GPS!« appears, shortly after the main menu is displayed

If the GPS status is not displayed, than

- the GPS function can be activated in the menu »settings« under menu item »device« (✓).

- Confirm the »Measuring« mode by pressing the  key
 ⇒ On the display the note »Connecting BLUETOOTH« appears.
 The Bluetooth pairing between settlement measuring instrument and GPS receiver will be established and the coordinates will be submitted. When storing the measuring results the submitted coordinates are automatically saved.
 ⇒ The user information »Precompact three times please!« appears.
- Conduct the measurement corresponding to instruction manual.
- Switch off GPS receiver (press On/Off button (1) for about 2 seconds).



The GPS receiver has to be switched off after each measuring. Before any further measuring, GPS receiver has to be switched on again.



If in the measuring instrument the GPS function is activated and the GPS receiver is not connected or not ready, the note »Power on GPS! Enter« or »No GPS-position« appears. Now the measuring process can be aborted or continued without the acquisition of GPS-data.

When printing out the measuring results via thermal printer, the position coordinates are automatically added.

The measuring results and corresponding coordinates can be printed out immediately at the site or can be transferred to the PC for subsequent processing.

If the GPS receiver shall not be used, prior to measurement the GPS function of the measuring instrument has to be deactivated.



In case there is no Bluetooth pairing established the GPS receiver will be switched off after ten minutes for power saving.

Cleaning

Care must be exercised when measuring to ensure there is no higher-than-normal dirt induced friction between the drop-weight and the guide tube; otherwise, incorrect data will be measured.

- Thoroughly clean the LWD after every use.
- Wipe the guide tube with soft cloth slightly soaked in oil.
- Then, move the drop-weight up and down on the guide tube.



Do not use grease to clean the guide tube.



The load plate must not be immersed in water; otherwise the sensor could be damaged.

Calibrating

The company of HMP is an authorised testing institution and calibration laboratory within the meaning of »Technical Test Code for Soil and Rock in Road Construction TP BF-StB Part B 8.4 / Issue 2016«.

The loading mechanism and the settlement measuring instrument of the LWD were calibrated prior to shipment ex works.

Calibration ensures both, the function of the equipment and compliance with the specifications for the loading mechanism and for the settlement measuring instrument.



**Re-calibration is required at least annually.
Also, re-calibration is essential after any repair of the LWD.**

The company of HMP has calibrated (DKD-supervised) instrumentation used to conduct force and distance calibrations. In addition, repairs necessary might be carried out.

The user should check the height of fall indicated in the calibration record, at intervals of three months.

Hotline

HMP Magdeburger Prüfgerätebau GmbH
 Bülstringer Straße 6
 D-39126 Magdeburg

Tel.: (03 91) 2 51 46 66
 (03 91) 2 51 46 67
 Fax: (03 91) 2 51 46 68
 E-Mail: info@hmp-online.de
<http://www.hmp-online.com>